



# 4SD

SUBMERSIBLE SEWAGE PUMP

DUAL SEAL WITH SEAL SENSOR PROBE

### FEATURES

**Impeller:** Cast iron, two vane semi-open, non-clog with pump-out vanes for mechanical seal protection. Balanced for smooth operation. Silicon bronze impeller available as an option.

**Casing:** Heavy duty cast iron, volute type for maximum efficiency. 4" flange conforms to 125 # ANSI standard. Connects to A10-40 or A10-60 guide rail system.

**Dual Mechanical Seals:** Silicon carbide vs. silicon carbide outer seal and ceramic vs. carbon inner seal, stainless steel metal parts, BUNA-N elastomers. Upper and lower shaft seals are positioned independently and are separated by an oil-filled chamber.

**Seal Sensor Probe:** Located in oil-filled chamber. If pumpage should begin to leak past lower seal it indicates to pump control panel a fault has occurred. **Requires optional Seal Fail Circuit in the control panel.**

**Shaft:** 300 series stainless steel keyed design.

**Fasteners:** 300 series stainless steel.

Capable of running dry without damage to components.

### AGENCY LISTINGS



Tested to UL 778 and CSA 22.2 108 Standards  
By Canadian Standards Association  
File #LR38549

### APPLICATIONS

Used in a variety of residential, commercial and industrial applications such as:

- Sewage systems
- Flood and pollution control
- Dewatering/Effluent
- Farms
- Hospitals
- Trailer courts
- Motels

### SPECIFICATIONS

#### Pump:

- Maximum solid size: 3"
- Discharge size: 4", 125 # ANSI flange
- Maximum capacity: 620 GPM
- Maximum total head: 60 feet
- 300 Series stainless steel fasteners
- 20' Power cord
- Standard silicon carbide/silicon carbide outer seal

#### Motor:

- Maximum ambient temperature: 104° F (40° C) continuous duty, 140° F (60° C) intermittent duty
- Rated for continuous duty when fully submerged
- Insulation: Class F
- 60 Hertz
- Single row ball bearings
- 300 Series stainless steel keyed shaft

#### Single Phase:

- 1.5 - 5 HP
- 208 and 230 volts
- Built-in thermal overloads with automatic reset
- Built-in capacitors

#### Three Phase:

- 1.5 - 7.5 HP
- 200, 230, 460 and 575 volts
- Class 10 overload protection must be provided in control panel

### MOTORS

- Fully submerged in oil-filled chamber. High grade turbine oil surrounds motor for more efficient heat dissipation, permanent lubrication of bearings and mechanical seal for complete protection against outside environment.
- **Class F insulation**
- **Designed for Continuous Operation:** Pump ratings are within the motor manufacturer's recommended working limits and can be operated continuously without damage when fully submerged.
- **Bearings:** Upper and lower heavy duty ball bearing construction for precision positioning of parts and to carry thrust loads.
- **Power and Control Cables:** Severe duty rated, oil and water resistant. Epoxy seal on motor end provides secondary moisture barrier in case of outer jacket damage and to prevent oil wicking. 20 foot standard with optional lengths available.
- **O-ring:** Assures positive sealing against contaminants and oil leakage.

### MODEL AND MOTOR INFORMATION

| Order No. | HP  | Phase | Volts | RPM  | Impeller   |      | Maximum Amps | L.R. Amps | KVA Code | Power Cable | F.L. Motor Efficiency % | Resistance |           | Weight (lbs.) |
|-----------|-----|-------|-------|------|------------|------|--------------|-----------|----------|-------------|-------------------------|------------|-----------|---------------|
|           |     |       |       |      | Dia. (in.) | Code |              |           |          |             |                         | Start      | Line-Line |               |
| 4SD52F8EA | 1.5 | 1     | 208   | 1750 | 5.63       | E    | 17.2         | 50.8      | B        | 14/3        | 80                      | 1.1        | 0.9       | 195           |
| 4SD52F1EA |     |       | 230   |      |            |      | 14.7         | 29.5      | E        |             | 70                      | 1.4        | 1.8       |               |
| 4SD52F2EA |     | 3     | 200   |      |            |      | 11.5         | 40.9      | H        | 14/4        | 81                      | NA         | 1.7       |               |
| 4SD52F3EA |     |       | 230   |      |            |      | 10.0         | 40.0      | F        |             | 83                      |            | 2.3       |               |
| 4SD52F4EA |     |       | 460   |      |            |      | 5.0          | 20.0      | F        |             | 83                      |            | 9.3       |               |
| 4SD52F5EA |     |       | 575   |      |            |      | 4.0          | 14.4      | H        |             | 74                      |            | 14.8      |               |
| 4SD52F8DA | 1.5 | 1     | 208   | 1750 | 6.25       | D    | 17.2         | 50.8      | B        | 14/3        | 80                      | 1.1        | 0.9       | 195           |
| 4SD52F1DA |     |       | 230   |      |            |      | 14.7         | 29.5      | E        |             | 70                      | 1.4        | 1.8       |               |
| 4SD52F2DA |     | 3     | 200   |      |            |      | 11.5         | 40.9      | H        | 14/4        | 81                      | NA         | 1.7       |               |
| 4SD52F3DA |     |       | 230   |      |            |      | 10.0         | 40.0      | F        |             | 83                      |            | 2.3       |               |
| 4SD52F4DA |     |       | 460   |      |            |      | 5.0          | 20.0      | F        |             | 83                      |            | 9.3       |               |
| 4SD52F5DA |     |       | 575   |      |            |      | 4.0          | 14.4      | H        |             | 74                      |            | 14.8      |               |
| 4SD52G8CA | 2   | 1     | 208   | 1750 | 6.63       | C    | 20.3         | 50.8      | B        | 14/3        | 80                      | 1.1        | 0.9       | 200           |
| 4SD52G1CA |     |       | 230   |      |            |      | 17.3         | 36.9      | D        |             | 75                      | 1.4        | 1.5       |               |
| 4SD52G2CA |     | 3     | 200   |      |            |      | 13.3         | 40.9      | H        | 14/4        | 81                      | NA         | 1.7       |               |
| 4SD52G3CA |     |       | 230   |      |            |      | 11.6         | 40.0      | F        |             | 83                      |            | 2.3       |               |
| 4SD52G4CA |     |       | 460   |      |            |      | 5.8          | 20.0      | F        |             | 83                      |            | 9.3       |               |
| 4SD52G5CA |     |       | 575   |      |            |      | 4.6          | 14.4      | H        |             | 74                      |            | 14.8      |               |
| 4SD52H8BA | 3   | 1     | 208   | 1750 | 7.00       | B    | 25.5         | 50.8      | B        | 10/3        | 80                      | 1.1        | 0.9       | 208           |
| 4SD52H1BA |     |       | 230   |      |            |      | 21.5         | 46.4      | C        | 79          | 1.0                     | 1.0        |           |               |
| 4SD52H2BA |     | 3     | 200   |      |            |      | 16.6         | 53.8      | G        | 10/4        | 85                      | NA         | 1.3       |               |
| 4SD52H3BA |     |       | 230   |      |            |      | 14.4         | 49.5      | H        | 14/4        | 83                      |            | 1.9       |               |
| 4SD52H4BA |     |       | 460   |      |            |      | 7.2          | 24.8      | H        |             | 83                      |            | 7.5       |               |
| 4SD52H5BA |     |       | 575   |      |            |      | 5.8          | 17.3      | G        | 78          | 11.6                    |            |           |               |
| 4SD52J1AA | 5   | 1     | 230   | 1750 | 7.25       | A    | 26.5         | 57.7      | A        | 10/3        | 80                      | 1.0        | 0.8       | 213           |
| 4SD52J2AA |     |       | 200   |      |            |      | 19.1         | 73.9      | F        | 10/4        | 84                      | 0.9        |           |               |
| 4SD52J3AA |     | 3     | 230   |      |            |      | 16.6         | 63.6      | E        | 14/4        | 85                      | NA         | 1.2       |               |
| 4SD52J4AA |     |       | 460   |      |            |      | 8.3          | 31.8      | E        |             | 85                      |            | 4.8       |               |
| 4SD52J5AA |     |       | 575   |      |            |      | 6.6          | 22.8      | E        |             | 80                      |            | 7.4       |               |
| 4SD52K3FA |     |       | 7.5   |      |            |      | 3            | 230       | 1750     |             | 7.69                    |            | F         | 23.0          |
| 4SD52K4FA | 460 | 11.5  |       | 52.5 | G          | 10/4 |              | 83        |          | 2.8         |                         |            |           |               |
| 4SD52K5FA | 575 | 9.2   |       | 42.0 | E          | 84   |              | 4.4       |          |             |                         |            |           |               |

### NOMENCLATURE DESCRIPTION

#### 1st, 2nd and 3rd Character - Discharge Size and Type

4SD = 4" discharge, 3" solids handling, dual seal with seal fail probe in pump.

#### 4th Character - Mechanical Seals

5 = Silicon carbide/silicon carbide/BUNA - lower seal and carbon/ceramic/BUNA - upper seal (standard)

3 = Silicon carbide/tungsten carbide/BUNA - lower seal and carbon/ceramic/BUNA - upper seal (optional)

#### 5th Character - Cycle/RPM

2 = 60 Hz/1750 RPM    6 = 50 Hz/1450 RPM

#### 6th Character - Horsepower

F = 1½ HP    H = 3 HP    K = 7½ HP

G = 2 HP    J = 5 HP

#### 7th Character - Phase/Voltage

1 = single phase, 230 V    4 = three phase, 460 V

2 = three phase, 200 V\*    5 = three phase, 575 V

3 = three phase, 230 V    8 = single phase, 208 V

\* Not available on 7½ HP.

#### 8th Character - Impeller Diameter

A = 7.25", 5 HP

D = 6.25", 1½ HP

B = 7.00", 3 HP

E = 5.63", 1½ HP

C = 6.63", 2 HP

F = 7.69", 7½ HP

#### 9th Character - Cord Length (Power and Sensor)

A = 20' (standard)

F = 50'

D = 30'

J = 100'

#### 10th Character - Options

B = Bronze impeller

E = Epoxy paint

F = Both epoxy paint and bronze impeller

#### 11th Character - Option

H = Pilot duty thermal sensors

## APPLICATION DATA

|                                   |  |
|-----------------------------------|--|
| Maximum Solid Size                | 3"   |
| Minimum Casing Thickness          | 5/16"  |
| Casing Corrosion Allowance        | 1/8"   |
| Maximum Working Pressure          | 30 PSI   |
| Maximum Submergence               | 50 feet  |
| Minimum Submergence               | Fully submerged for continuous operation         |
|                                   | 6" below top of motor for intermittent operation |
| Maximum Environmental Temperature | 40°C (104°F) continuous operation                |
|                                   | 60°C (140°F) intermittent operation              |

## CONSTRUCTION DETAILS

|                                      |   |
|--------------------------------------|---|
| Power Cable - Type                   | 14/3, type SJTOW: single phase, 1/2 and 2 HP  |
|                                      | 14/4, type STOW: single phase, 1 1/2 - 3 HP and 5 HP, 460 V   |
|                                      | 10/4, type STOW: single phase, 3 and 5 HP, three phase 5 HP, 230 V and 7 1/2 HP   |
| Sensor Cable - Type                  | 16/2, type SJTOW: seal sensor only  |
|                                      | 18/4, type SJTOW: seal/heat sensor  |
| Motor Cover                          | Gray Cast Iron - ASTM A48 Class 30  |
| Bearing Housing                      | Gray Cast Iron - ASTM A48 Class 30  |
| Seal Housing                         | Gray Cast Iron - ASTM A48 Class 30  |
| Casing                               | Gray Cast Iron - ASTM A48 Class 30  |
| Impeller                             | Gray Cast Iron - ASTM A48 or Cast Bronze - ASTM B584 C87600   |
| Motor Shaft                          | AISI 300 Series Stainless Steel   |
| Motor Design                         | NEMA 56 Frame, oil filled with Class F Insulation   |
| Motor Overload Protection            | Single Phase: on winding thermal overload protection  |
|                                      | Three Phase: require ambient compensated Class 10, quick trip overloads in the control panel.   |
| Motor Seal Fail (Moisture) Detection | Seal fail sensor in an oil-filled seal chamber. Connect to an optional relay in control panel.  |
| Optional Motor Thermal Protection    | Normally closed on-winding thermostats open at 275° F (135 °C) and close at 112° F (78° C). Require terminal connection in the control panel. |
| External Hardware                    | 300 Series Stainless Steel  |
| Impeller Type                        | Semi-open with pump out vanes on back shroud  |
| Oil Capacity - Seal Chamber          | 1.75 quarts   |
| Oil Capacity - Motor Chamber         | 1 1/2-5 HP single and three phase: 7 quarts   |
|                                      | 7 1/2 HP three phase: 6.5 quarts  |

## STANDARD PARTS

|                                   |       |   |
|-----------------------------------|-------|---|
| Ball Bearing                      | Upper | 1 1/2 - 5 HP single and three phase: single row ball- SKF™ 6204-2Z  |
|                                   |       | 7 1/2 HP three phase: single row ball - SKF™ 6204-2Z                |
| Ball Bearing                      | Lower | 1 1/2 - 5 HP single and three phase: single row ball - SKF™ 5206-2Z |
|                                   |       | 7 1/2 HP three phase: double row ball - SKF™ 5206-2Z                |
| Mechanical Seals - Standard       | Upper | Carbon/Ceramic; Type 21   |
|                                   | Lower | Silicon Carbon/Silicon Carbon; Type 31                              |
| Mechanical Seals - Optional Lower |       | Silicon Carbide/Tungsten Carbide: Type 21                           |
| O-Ring - Stuffing Box             |       | BUNA-N, AS 568A-265   |
| O-Ring - Motor Cover              |       | BUNA-N, AS 568A-374   |

## DIMENSIONS

(All dimensions are in inches. Do not use for construction purposes.)

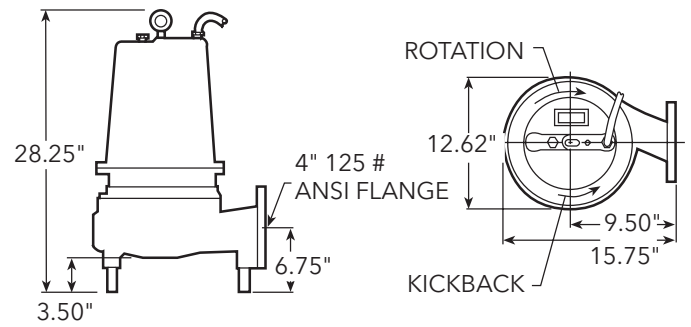

## MATERIALS OF CONSTRUCTION

| Item No.             | Part Name               | Material                      |                 |                   |                    |                    |
|----------------------|-------------------------|-------------------------------|-----------------|-------------------|--------------------|--------------------|
|                      |                         | Standard                      | Optional        |                   |                    |                    |
| 1                    | Impeller, non-clog      | 1003                          | 1179            |                   |                    |                    |
| 2                    | Castings                | 1003                          |                 |                   |                    |                    |
| 3                    | Shaft-Keyed             | 300 Series SS                 |                 |                   |                    |                    |
| 4                    | Fasteners               | 300 Series SS                 |                 |                   |                    |                    |
| 5                    | Ball bearings           | Steel                         |                 |                   |                    |                    |
| 6                    | Power cable             | STOW, 20 feet                 |                 |                   | Additional lengths |                    |
|                      | Seal sensor cable       |                               |                 |                   |                    |                    |
| 7                    | O-ring                  | BUNA-N                        |                 |                   |                    |                    |
| 8                    | <b>Outer Mech. Seal</b> | <b>Service</b>                | <b>Rotary</b>   | <b>Stationary</b> | <b>Elastomers</b>  | <b>Metal Parts</b> |
|                      | OPT                     | Heavy duty                    | Silicon Carbide | Tungsten Carbide  | BUNA-N             | 300 Series SS      |
|                      | STD                     | Mild abrasives                | Silicon Carbide |                   | BUNA-N             | 300 Series SS      |
| <b>Material Code</b> |                         | <b>Engineering Standard</b>   |                 |                   |                    |                    |
| 1003                 |                         | Cast iron - ASTM A48 Class 30 |                 |                   |                    |                    |
| 1179                 |                         | Silicon bronze - ASTM C87600  |                 |                   |                    |                    |

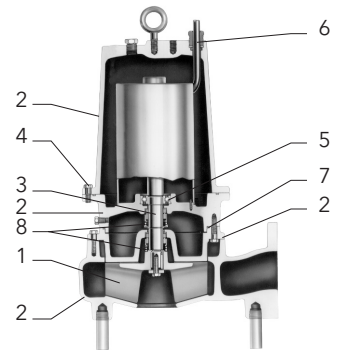

**xylem**  
Let's Solve Water

Xylem, Inc.  
2881 East Bayard Street Ext., Suite A  
Seneca Falls, NY 13148  
Phone: (866) 325-4210  
Fax: (888) 322-5877  
[www.xylem.com/brands/gouldswatertechnology](http://www.xylem.com/brands/gouldswatertechnology)

Goulds is a registered trademark of Goulds Pumps, Inc. and is used under license.  
© 2012 Xylem Inc. B4SD May 2012